

SMaLL Printer

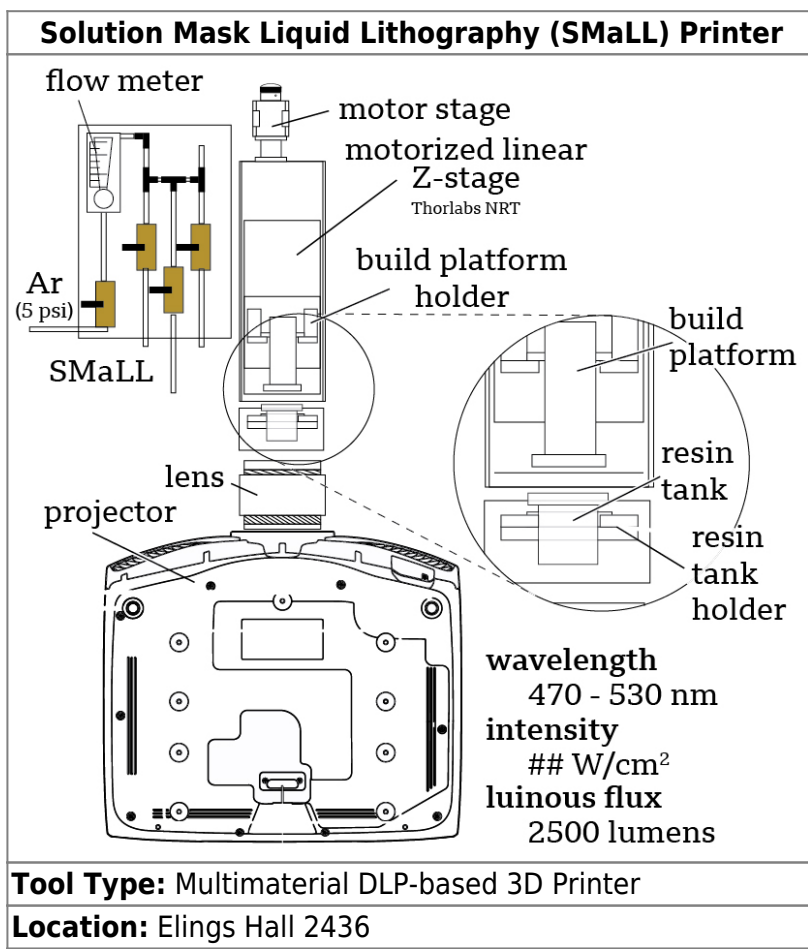

Supervisor
Juan Manuel Uruena
jmurueña@ucsb.edu

About

SMaLL is capable of creating unique structures with mechanically and chemically distinct regions. By using tunable, visible wavelength photoswitches, in combination with orthogonal crosslinking reactions, a single resin formulation can be employed for the facile, one-step printing of complex, bioinspired structures. The fabrication of soft joints and brick-and-mortar architectures showcase the utility of SMaLL for printing all-polymer composites with well-defined regions for different mechanical and chemical properties.

Detailed Specifications

- Wavelength: 420 - 700 nm
- Luminous flux: 2,500 lumens
- Projector: Epson PowerLite Home Cinema 5040UB

- 1080p native resolution with 4K Enhancement

Safety Concerns

Read the manufactures manual before first use. If the BIO X Cellink acts in a way that is not described by the manual, turn off the printer and contact CELLINK.

- Never place your finger near the machine until all parts have stopped moving. Moving parts can cause serious injury
- Never clean or service the printer while it is on
- The printer uses UV light for sterilization and curing. Never look directly at UV light nor expose skin. Serious injury may result from exposure
- The printer has heated surfaces that can reach temperature up to 250 degrees Celsius. Never touch these surfaces when using the heating function. Allow things to cool before opening, touching the printer
- Always ensure that equipment is correctly mounted before use. Improperly mounted print beds, printheads, cartridges, calbes liquid spouts and air spouts can be dangerous. If any equipment appears damaged, turn off the printer, unplug all connections and contact CELLINK.

Reference Documentation

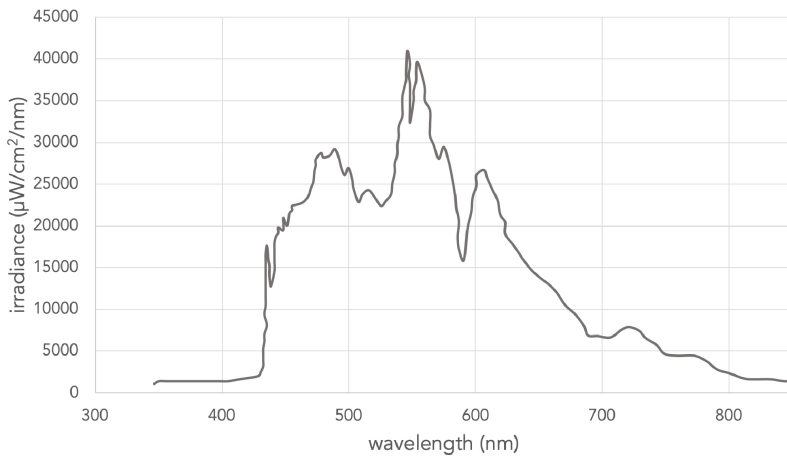

Creation Workshop Manual

SMaLL Projector Manual

From:

<https://bpm-wiki.cnsi.ucsb.edu/> - NSF BioPACIFIC MIP Wiki

Permanent link:

https://bpm-wiki.cnsi.ucsb.edu/doku.php?id=small_printer&rev=1728580210

Last update: **2024/10/10 17:10**



